

➤ PRODUCT SELECTION & INSTALLATION GUIDE

# Ballistic Resistant Composite Panels



## KEY CHARACTERISTICS

### Military grade protection

Ballistic resistant composite panels from Avient are constructed to provide military-grade protection from armed attackers for any facility. Originally developed for protection from mortar fire, fiber-reinforced composite panels offer superior ballistic resistance at less than 25% of the weight of a comparable steel panel.

### Resistant security

The unique composite matrix of the panels allows for retention of the projectile to avoid potentially hazardous ricochet. These fiber-reinforced panels offer ballistic resistant security with additional performance advantages, including durability, corrosion resistance, electrical non-conductivity, low thermal conductivity, and reduced weight.

## PRODUCT DESCRIPTION

**GlasArmor™ thermoset panels** are constructed from layers of 0°/90° woven E-glass fiber reinforcements with a proprietary resin system. Panels are available for protection to UL 752 levels 1, 2, & 3 and NIJ Levels I, II, & IIIA test standards for ballistic resistance. Additionally, these UL 752 level 3 panels provide Class 3.7 (Contraband) and Class 5.0 (Body) Forced Entry Physical Attack Ratings per ASTM F1233-21.

**ThermoBallistic™ thermoplastic panels** are thermally formed with layers of 0°/90° unidirectional E-glass fiber reinforcements with polyolefin-based resin systems and are available for protection to UL 752 level 3.

Additional protection against higher power ammunitions can be achieved by layering multiple panels; contact Avient for more information regarding your specific application.

## CUSTOMIZED SOLUTIONS

Our custom capabilities include:

- Drilling
- Routing
- Machining
- Finishing
- Custom colors
- Unique panel sizes

## USES AND APPLICATIONS

Composite ballistic panels from Avient are suitable for indoor and outdoor use in commercial, governmental, industrial, and residential applications:

- Military structures
- Infrastructure facilities and equipment
- Banks
- Check cashing stations
- Pawn shops
- Loan and bail/bond offices
- Courtrooms
- Police stations
- Detention facilities
- Bonded warehousing
- Security buildings
- Equipment shielding locations
- Safe rooms
- Storm shelters
- Judges' chambers

## UL 752 & NIJ STANDARDS FOR BALLISTIC RESISTANT PROTECTIVE MATERIALS

UL Rating	NIJ Level	Ammunition	Velocity	No. Shots	Composite Panel	Nominal Thickness	Nominal Weight
Level 1		9mm full metal copper jacket with lead core	1175 ft/sec 358 m/sec	3	GlasArmor Level 1	0.256 in 6.5 mm	2.7 lb/ft <sup>2</sup> 13.2 kg/m <sup>2</sup>
					ThermoBallistic Level 1	0.23 in 5.8 mm	1.95 lb/ft <sup>2</sup> 9.52 kg/m <sup>2</sup>
Level 2	Level II-A	.357 magnum jacketed lead soft point	1250 ft/sec 381 m/sec	3	GlasArmor Level 2	0.384 in 9.8 mm	4.0 lb/ft <sup>2</sup> 19.5 kg/m <sup>2</sup>
					ThermoBallistic Level 2	0.34 in 8.6 mm	2.92 lb/ft <sup>2</sup> 14.3 kg/m <sup>2</sup>
Level 3	Level III-A	.44 magnum lead semi-wadcutter gas checked	1350 ft/sec 411 m/sec	3	GlasArmor Level 3*	0.500 in 12.7 mm	5.4 lb/ft <sup>2</sup> 26.4 kg/m <sup>2</sup>
					ThermoBallistic Level 3	0.440 in 11.2 mm	3.9 lb/ft <sup>2</sup> 19.0 kg/m <sup>2</sup>
Level 4		.30 cal. rifle lead core	2450 ft/sec 747 m/sec	1	* Class 3.7 (Contraband) and Class 5.0 (Body) Forced Entry Physical Attack Ratings per ASTM F1233-21  Customized solutions are available. Contact Avient for application-specific information.		
Level 5		7.62mm rifle lead core full metal copper jacket, military ball	2750 ft/sec 838 m/sec	1			
Level 6	Level II	9mm full metal jacket with lead core	1400 ft/sec 427 m/sec	5			
Level 7		5.56mm rifle full metal copper jacket with lead core	3080 ft/sec 939 m/sec	5			
Level 8	Level III	7.62mm rifle lead core full metal copper jacket, military ball	2750 ft/sec 838 m/sec	5			



## BALLISTIC PANEL SELECTION GUIDE

Width	Length	Thickness	Color
<b>LEVEL 1</b>			
<b>GlasArmor Panels</b>			
36 in/91 cm	96 in/244 cm	0.256 in/6.5 mm	Natural
36 in/91 cm	120 in/305 cm		
48 in/122 cm	96 in/244 cm		
48 in/122 cm	108 in/274 cm		
48 in/122 cm	120 in/305 cm		
<b>LEVEL 2</b>			
<b>GlasArmor Panels</b>			
36 in/91 cm	96 in/244 cm	0.384 in/9.8 mm	Natural
36 in/91 cm	120 in/305 cm		
48 in/122 cm	96 in/244 cm		
48 in/122 cm	108 in/274 cm		
48 in/122 cm	120 in/305 cm		
<b>LEVEL 3</b>			
<b>GlasArmor Panels</b>			
36 in/91 cm	96 in/244 cm	0.500 in/12.7 mm	Natural
36 in/91 cm	120 in/305 cm		Natural
48 in/122 cm	96 in/244 cm		Natural, Grey, White, Tan
48 in/122 cm	108 in/274 cm		Natural, Grey
48 in/122 cm	120 in/305 cm		Natural, Grey, White
<b>ThermoBallistic Panels</b>			
24 in/61 cm	96 in/244 cm	0.44 in/11.2 mm	Natural
24 in/61 cm	144 in/366 cm		
48 in/122 cm	96 in/244 cm		
48 in/122 cm	144 in/366 cm		

Customized panel sizes and colors available. Contact Avient for information.



## INSTALLATION INSTRUCTIONS

Ballistic resistant panels can be field-fabricated using simple installation methods and common carpentry tools. Proper installation is necessary to achieve optimum ballistic resistance.

1. Lay out the project to utilize the largest panel sizes to minimize the number of seams.
2. Fabricate the GlasArmor panels to the desired size by cutting with a circular saw equipped with a diamond abrasive blade. ThermoBallistic panels should be cut using a wood cutting blade with +/-45 degree teeth. Be sure to wear appropriate safety equipment including safety glasses and dust masks when fabricating.
3. Secure the panels to steel or wood framing by mechanically fastening with heavy-duty wallboard or lag screws.
4. When constructing walls, rest the initial course of panels firmly on the floor to avoid any unsupported panel weight on the wall framing.
5. Reinforce all panel seams with a minimum 4 inch (10.16 cm ) batten of additional ballistic panel material. Position these batten strips to cover the seam and attach to both panels using appropriate wallboard screws (see diagram).
6. Use overlapping butt joints when installing panels into corners.
7. Panels expand to absorb ballistic impact. When covering a sensitive substructure such as glass, shim the panels 3/8 inch (9.5 mm) to prevent impact shock damage.
8. Panels can be finished by covering with drywall, paneling, painting, or wall covering. Painting or wall covering will require the use of a suitable primer. When applicable, fire tests shall be performed on a finished wall system.

### TYPICAL PANEL JOINT DETAIL

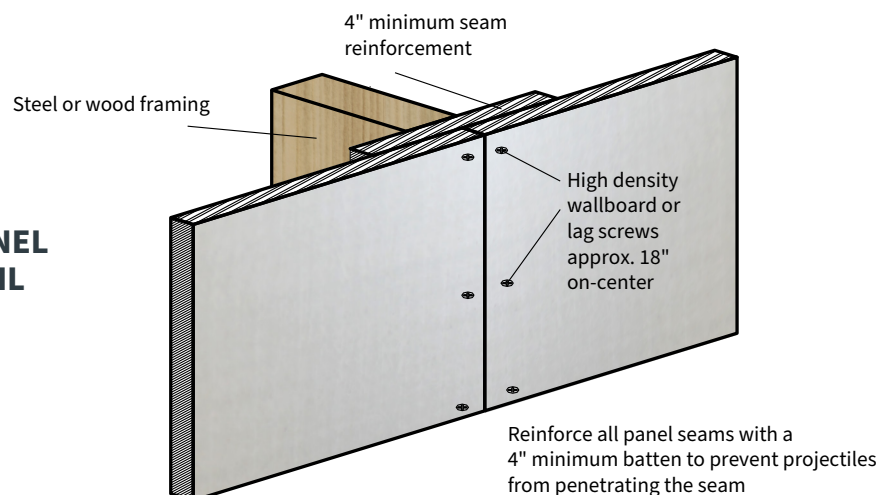

## MATERIAL DATA (TYPICAL VALUES)

Property	GlasArmor Panel	ThermoBallistic Panel	Test Method
Glass Content	55 wt%	73 wt%	n/a
Density	0.066 lb/in <sup>3</sup> 1.83 g/cm <sup>3</sup>	0.062 lb/in <sup>3</sup> 1.72 g/cm <sup>3</sup>	ASTM D-792
Flex Mod	2.1–2.7 msi 14.5 - 18.6 GPa	2.5 msi 17.2 GPa	ASTM D-790
Flex Strength	65 ksi 448 MPa	14 ksi 96.5 MPa	ASTM D-790
Barcol Hardness	50–60	n/a	ASTM D-2583
Fire Rating	1 hour <sup>1</sup>	n/a	ASTM E-119-09c
Flame Spread Rating	45 <sup>2</sup>	n/a	ASTM E-84-08a
Smoke Developed Rating	165 <sup>2</sup>	n/a	ASTM E-84-08a
Forced Entry Physical Attack Rating - Contraband	3.7 <sup>3</sup>	n/a	ASTM F-1233-21
Forced Entry Physical Attack Rating - Body	5.0 <sup>4</sup>	n/a	ASTM F-1233-21

<sup>1</sup> UL Level 3 panel was fire tested as part of a wall system with steel studs and drywall face sheet

<sup>2</sup> NFPA & IBC Class B rating achieved

<sup>3</sup> Contraband was represented by a 1/8 in. diameter rod

<sup>4</sup> Body was represented by an 8 in. x 8 in. x 5 in. solid uncompressible rectangular object



**To learn more about Avient ballistic panel applications and solutions, please call +1.844.4AVIENT (+1.844.428.4368).**

[www.avient.com](http://www.avient.com)



Copyright © 2026, Avient Corporation. Avient makes no representations, guarantees, or warranties of any kind with respect to the information contained in this document about its accuracy, suitability for particular applications, or the results obtained or obtainable using the information. Some of the information arises from laboratory work with small-scale equipment which may not provide a reliable indication of performance or properties obtained or obtainable on larger-scale equipment. Values reported as intypical in or stated without a range do not state minimum or maximum properties; consult your sales representative for property ranges and min/max specifications. Processing conditions can cause material properties to shift from the values stated in the information. Avient makes no warranties or guarantees respecting suitability of either Avient's products or the information for your process or end-use application. You have the responsibility to conduct full-scale end-product performance testing to determine suitability in your application, and you assume all risk and liability arising from your use of the information and/or use or handling of any product. AVIENT MAKES NO WARRANTIES, EXPRESS OR IMPLIED, INCLUDING, BUT NOT LIMITED TO, IMPLIED WARRANTIES OF MERCHANTABILITY AND FITNESS FOR A PARTICULAR PURPOSE, either with respect to the information or products reflected by the information. This literature shall NOT operate as permission, recommendation, or inducement to practice any patented invention without permission of the patent owner.